



The European B2B Forum for the Electronics Industry

## **EDIFICE Message Implementation Guideline**

### **Authorisation Status**

**ATHSTS Issue EDAS03**

**Endorsed 27 November 2002**

**To be proposed as a UN/EDIFACT Standard Message**

Copyright ©EDIFICE 2004

All rights reserved. No part of this publication may be reproduced or transmitted in any form or by any means without prior permission of EDIFICE.

Notwithstanding the fact that the utmost care has been observed in the collecting, drawing up and formulating of data, EDIFICE can under no circumstances be held liable for errors, omissions or misinterpretations as a result of the information compiled in the guidelines.

EDIFICE  
The European B2B Forum for the Electronics Industry  
EDIFICE secretariat  
Dora Cresens  
Tiensestraat 2  
B-3320 Hoegaarden  
Belgium  
Tel: +32 16 76 54 40  
Fax: +32 16 76 53 58  
Email: [Dora.Cresens@edifice.org](mailto:Dora.Cresens@edifice.org)

## **TABLE OF CONTENTS**

<u>TITLE</u>	<u>PAGE</u>
COMPARISON TO PREVIOUS ISSUE	3
EDIFICE FUNCTIONAL DEFINITION	5
REFERENCES	8
EXPLANATORY NOTES	8
MESSAGE STRUCTURE CHART	9
BRANCHING DIAGRAM	10
SEGMENT GROUPS/SEGMENTS DESCRIPTION	12
UNH           MESSAGE HEADER	14
BGM           BEGINNING OF MESSAGE	15
DTM           DATE/TIME/PERIOD	16
NAD           NAME AND ADDRESS	17
SG1 - DOC     DOCUMENT/MESSAGE DETAILS	18
SG1 - DTM     DATE/TIME/PERIOD	19
SG1 - NAD     NAME AND ADDRESS	20
SG1 - RFF     REFERENCE	21
SG1 - CUX     CURRENCIES	22
SG2 - LIN     LINE ITEM	23
SG2 - PIA     ADDITIONAL PRODUCT ID	24
SG2 - RFF     REFERENCE	25
SG2 - DTM     DATE/TIME/PERIOD	26
SG2 - QTY     QUANTITY	27
SG2 - PRI     PRICE DETAILS	28
UNT           MESSAGE TRAILER	29
EXAMPLES	30

## **COMPARISON TO PREVIOUS ISSUE**

12 May 2004 : EDIFIX 5.0 Technical upgrade

- The 'KMT' qualifier in SEG QTY and PRI DE 6411 is now defined as (\*) EDIFICE code. UN/ECE Recommendation 20 specifies 'KTM' as qualifier for 'kilometre'

21 May 2003 : EDIFIX 4.2 Technical upgrade; review and correction of examples

Issue EDAS03 of 13 November 2002 is based on UN/EDIFACT D97.A / Code List D01.A

- Addition of the following code value:

SG2, LIN segment, CO C212, DE 7143 codes 'SRV' EAN.UCC Global Trade Item Number  
SG2, PIA segment, CO C212, DE 7143 codes 'SRV' EAN.UCC Global Trade Item Number

Issue EDAS02; Publication date 29 May 2002 – addition of recommended set of DTM qualifiers

Issue EDAS02 of 26 November 1997 includes the changes that have been made to the issue 1 of the Authorisation Status document endorsed by the EDIFICE Plenary on 7 September 1994. The changes are as follows:

- Recast from the 92.1 version of the UN/EDIFACT directory to the D.97A version,

- Addition of the following code values:

all DTM segments, CO C507, DE 2379, code '203' CCYMMDDHHMM  
header NAD segment, CO C082, DE 3055, code '16' DUNS (Dun & Bradstreet)  
SG1, DTM segment, CO C507, DE 2005 code '36' Expiry date  
SG1, NAD segment, CO C082, DE 3055 codes '9' EAN (International Article Numbering association)  
    '16' DUNS (Dun & Bradstreet)  
    '91' Assigned by seller or seller's agent  
SG2, LIN segment, CO C212, DE 7143 codes 'DI' Distributor's part number  
    'MF' Manufacturer's (producer's) article number  
    'UP' UPC (Universal product code)  
SG2, LIN segment, CO C212, DE 3055 codes '89' Assigned by distributor  
    '90' Assigned by manufacturer  
    '113' US, UCC (Uniform Code Council)  
SG2, PIA segment, CO C212, DE 7143 codes 'DI' Distributor's part number  
    'MF' Manufacturer's (producer's) article number  
    'UP' UPC (Universal product code)  
SG2, PIA segment, CO C212, DE 3055 codes '89' Assigned by distributor  
    '90' Assigned by manufacturer  
    '113' US, UCC (Uniform Code Council)  
SG2, PRI segment, CO C509, DE 5125, code 'AAA' Calculation net,

- Deletion of the following code values:

SG2, PIA segment, CO C212, DE 7143, codes 'CCM' COCOM list number  
    'DR' Drawing revision number  
    'DW' Drawing  
    'EC' Engineering change level  
    'GS' General specification number  
    'SG' Standard group of products (mixed assortment)  
    'VX' Vendor specification number  
SG2, PRI segment, CO C509, DE 5125, codes 'CAT' Catalogue price  
    'NBP' New buy price  
    'RES' Resale price,

- Replacement of the following codes:

header NAD segment, DE 3035, codes 'MF' to 'SE' Seller  
    'DS' to 'BY' Buyer  
header NAD segment, CO C082, DE 3055, codes '89' to '92' Assigned by buyer or buyer's agent  
    '90' to '91' Assigned by seller or seller's agent  
SG1, DOC segment, CO C002, DE 1001, code 'ATH' to '173' Authorisation to plan and ship orders  
SG1, DTM segment, CO C507, DE 2005, codes '182' to '137' Document/message date/time  
    '401' to 'DLU' Date of last update  
SG1, NAD segment, DE 3035, code 'UD' to 'PC' Actual purchaser's customer  
SG1, NAD segment, CO C082, DE 3055, code '89' to '92' Assigned by buyer or buyer's agent  
SG1, RFF segment, CO C506, DE 1153, code 'BQ' to 'AHU' Request for quote number  
SG2, DTM segment, CO C507, DE 2005, code '401' to 'DLU' Date of last update  
SG2, QTY segment, CO C186, DE 6063, codes '301' to 'QAU' Quantity authorised  
    '302' to 'QCL' Quantity claimed  
    '303' to 'QBS' Quantity balance to ship,

- Usage changed for the following segments/data elements:

BGM segment, DE 1225, X to A  
header NAD segment, CO C082 R to A

SG1, DTM segment, R..2 to R..3  
SG2, DTM segment, R..3 to D..3  
SG2, PRI segment, CO C509, DE 5375, X to R  
SG2, PRI segment, CO C509, DE 5284, X to R,

- Where UN/ECE Recommendations are referenced the most commonly used codes have been identified,
- Alignment of segments and composite data elements to ensure conformance (data harmonization) across all EDIFICE Implementation Guidelines,
- Update of the EDIFICE FUNCTIONAL DEFINITION, REFERENCES and EXPLANATORY NOTES section to comply with the EDIFICE Standards for Documentation of Message Implementation Guidelines issue 3,
- Update of examples,
- Documentation adjustments resulting from the use of GEFEG's EdiFix Message Implementation Guidelines documentation tool,
- Correction of typographical errors.

## **EDIFICE FUNCTIONAL DEFINITION**

The business relationship can be between any buying and selling functions. For the purposes of this business scenario these buying and selling functions relate to a distributor and manufacturer respectively.

### 1. Typical business scenario

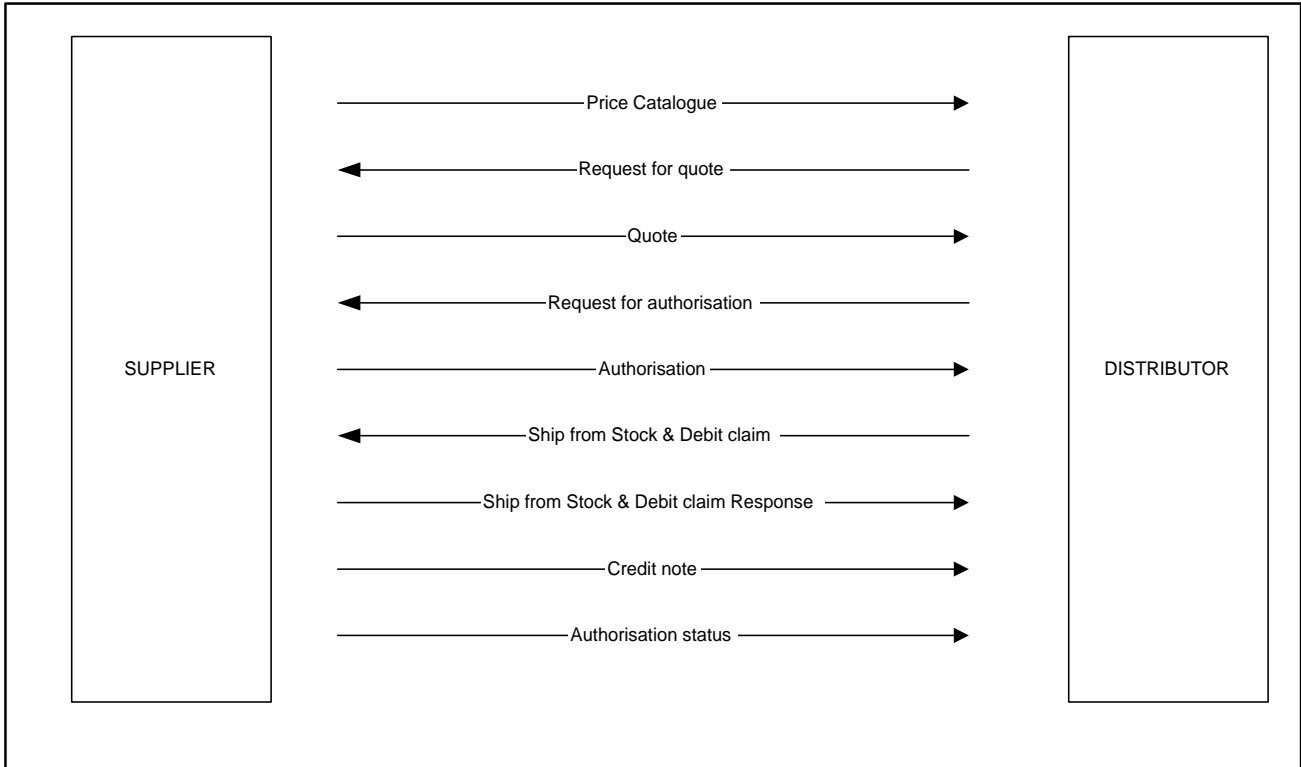

## 2. Description of the Ship from Stock & Debit business scenario

### 2.1 Stocking of Goods and Stock Protection

The distributor purchases the goods with the manufacturer for stocking purposes at a fixed price. These prices are fixed for a certain period of time e.g. prices are fixed per quarter. This purchase price is commonly referred to as 'distributor cost' or 'catalogue price'.

When the manufacturer decides to change his price, the following process is applied:  
Based on the distributor's inventory level at the time of the price change, the manufacturer can calculate the difference in value of the stock affected by the price change.

When, as in the majority of the cases, the prices of electronics components go down, the manufacturer will credit the distributor's account for the difference in value of his stock.

There are variances in the stock protection mechanism from one manufacturer to another. The exact conditions can usually be found in the franchise agreement. There are other implications to this stock protection mechanism e.g. stock return, which are not part of this scenario.

### 2.2 Request of a New Buy Price

The primary purpose for a distributor to have stock, is to sell the goods to his customers, referred to as the 'end-customers'.

Very often, the market price will have changed since the distributor bought the goods from a manufacturer which prevents the distributor from making a healthy margin. For this purpose, manufacturers introduced the 'Ship from Stock & Debit' scenario.

When a distributor has a business opportunity with an end-customer, he will inform the manufacturer of the business opportunity with a 'request for quote'.

The distributor will get a response from the manufacturer to his proposal - the 'quote'. In this quote, the manufacturer will propose a 'new buy price'. This 'new buy price' is only valid for the authorised quantity and the end-customer specified in the quote.

Based on this quote, the distributor can make a final offer to his end-customer. When the end-customer accepts the deal, which results in an order from the end-customer to the distributor, the distributor will inform the manufacturer of this deal, by phone, fax or EDI - 'request for authorisation'. The manufacturer will give the distributor a final authorisation to ship the goods and claim back the difference between the 'distributor cost' and the 'new buy price'. Besides the 'new buy price', the 'authorised quantity' and the 'end-customer', an 'expiry date' is always attached to the 'authorisation'.

Not all manufacturers require a 'four step' negotiation process. The process can be reduced to a 'three step' process if the first offer to the distributor already contains a conditional authorisation number.

### 2.3 Shipping to the End-customer / Claiming from the Manufacturer

Independent of how many steps the bid/offer process takes, it is only when the distributor starts shipping the goods to his end-customer that he can claim the difference between the 'distributor cost' and the 'new buy price' from the manufacturer.

The frequency at which a distributor makes a claim to the manufacturer differs. Some manufacturers allow the distributor to claim when the shipping event occurs, others ask the distributor to accumulate and transmit the claims on a fixed interval period e.g. weekly or monthly.

The manufacturer will receive the claim and process it against the distributor's 'open' authorisations. Not all claims are accepted based on the conditions stated in the claim. It is even possible that some claims are rejected.

The manufacturer will inform the distributor of the processing result of every claim. Finally the manufacturer will issue a credit note to the distributor and credit the distributor's account.

#### 2.4 Where does the Authorisation Status fit in this scenario?

The purpose of this message is to allow the manufacturer to inform his distributor of the status of the distributor's authorisations.

This EDIFICE implementation guideline is designed to be a snap-shot of the status of all authorisations at a given time.

The manufacturer can agree with his distributor to convey authorisation line items with one of the following statuses: 'open', 'expired', 'hold', 'closed'.

- Open authorisation line item:  
The item is available for the distributor to claim against.
- Expired authorisation line item:  
Although the item's quantity was not completely used, it has passed its expiry date.
- Hold the authorisation line item:  
The item is temporarily put on hold by the manufacturer. A claim against this item will be rejected.
- Closed authorisation line item:  
The item has passed its expiry date or all its quantity has been used. This status is final.

## **REFERENCES**

Refer to the document : Reference list for the EDIFICE message guidelines – Issue 1

## **EXPLANATORY NOTES**

Refer to the document : Explanatory notes for the EDIFICE message guidelines – Issue 1



## MESSAGE STRUCTURE CHART

	UNH	MESSAGE HEADER	M1
	BGM	BEGINNING OF MESSAGE	M1
	DTM	DATE/TIME/PERIOD	R1
	NAD	NAME AND ADDRESS	R..2
—	SG1		R..200000
	DOC	DOCUMENT/MESSAGE DETAILS	M1
	DTM	DATE/TIME/PERIOD	R..3
	NAD	NAME AND ADDRESS	R1
	RFF	REFERENCE	O..2
	CUX	CURRENCIES	R..2
—	SG2		R..200000
	LIN	LINE ITEM	M1
	PIA	ADDITIONAL PRODUCT ID	D..7
	RFF	REFERENCE	R1
	DTM	DATE/TIME/PERIOD	D..3
	QTY	QUANTITY	R..3
—	PRI	PRICE DETAILS	O..3
	UNT	MESSAGE TRAILER	M1

**BRANCHING DIAGRAM**

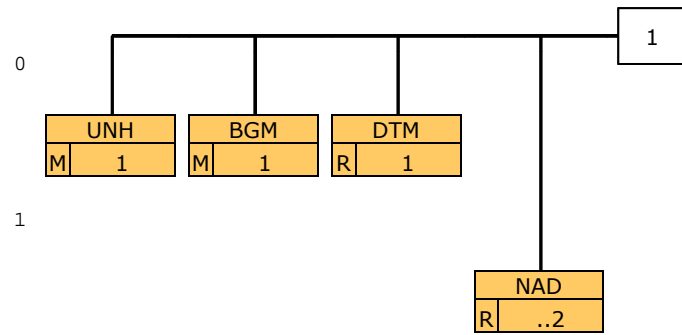

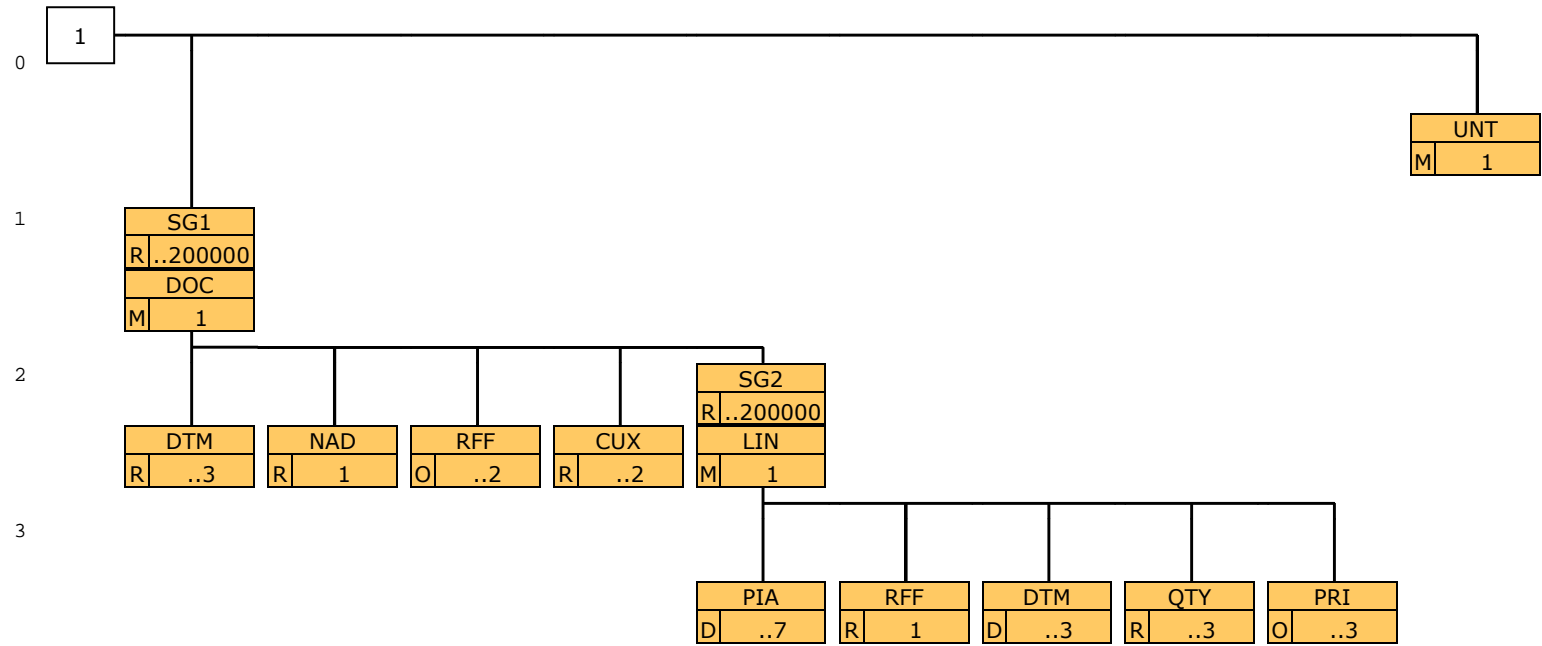

## **SEGMENT GROUPS/SEGMENTS DESCRIPTION**

### **UNH MESSAGE HEADER**

---

Function: A service segment heading, and uniquely identifying the message.  
Usage: M1

### **BGM BEGINNING OF MESSAGE**

---

Function: A segment uniquely identifying the message by means of its coded name, number and function.  
Usage: M1

### **DTM DATE/TIME/PERIOD**

---

Function: A segment specifying the date/time of creation of the message.  
Usage: R 1

### **NAD NAME AND ADDRESS**

---

Function: A segment identifying the function and coded identification, name and address of a party involved.  
Usage: R..2

### **SG1 DOC-DTM-NAD-RFF-CUX-SG2**

---

Function: A group of segments providing details of the individual items i.e. authorisations within the message.  
Usage: R..200000  
Notes:

### **DOC DOCUMENT/MESSAGE DETAILS**

---

Function: A segment specifying the authorisation number.  
Usage: M1

### **DTM DATE/TIME/PERIOD**

---

Function: A segment specifying the date/time of creation of the authorisation and other dates/times relevant to the authorisation.  
Usage: R..3

### **NAD NAME AND ADDRESS**

---

Function: A segment identifying the function and coded identification, name and address of the end-customer to whom the authorisation relates.  
Usage: R 1

### **RFF REFERENCE**

---

Function: A segment specifying the quote and/or request for quote number related to the authorisation.  
Usage: O..2

### **CUX CURRENCIES**

---

Function: A segment specifying a currency, valid for the whole authorisation.  
Usage: R..2

### **SG2 LIN-PIA-RFF-DTM-QTY-PRI**

---

Function: A group of segments providing status details of the individual line items within the authorisation.  
Usage: R..200000  
Notes: The PIA segment is dependent on whether the primary reference to the authorisation line item is insufficient to identify the item.  
The DTM segment is used when dates/times need to be specified for the line item.

### **LIN LINE ITEM**

---

Function: A segment identifying a line item by its item number, and agreed to be the primary reference number between the buyer and seller.  
The segment also carries a sequence number assigned to the line item within the message, and the action taken.  
Usage: M1

---

**PIA      ADDITIONAL PRODUCT ID**

Function: A segment providing additional identification numbers for the line item.  
Usage: D..7

---

**RFF      REFERENCE**

Function: A segment specifying the authorisation line number.  
Usage: R 1

---

**DTM      DATE/TIME/PERIOD**

Function: A segment specifying the expiry date/time, and other dates/times relevant to the line item.  
Usage: D..3

---

**QTY      QUANTITY**

Function: A segment specifying the quantity related to the line item.  
Usage: R..3

---

**PRI      PRICE DETAILS**

Function: A segment specifying the line item price and qualifying information.  
Usage: O..3

---

**UNT      MESSAGE TRAILER**

Function: A service segment ending, and providing information for checking the completeness of a message.  
Usage: M1

## SEGMENT DETAILS



### **UNH MESSAGE HEADER**

Function: A service segment heading, and uniquely identifying the message.

Usage : M1

Notes : Refer to EDIFICE Utilisation of the UN/EDIFACT Service Segments, Issue EDSS04

Ref.	Rep.	Name		EDIFICE Utilisation
0062	an..14	M MESSAGE REFERENCE NUMBER	M	Transmission message count from 1
S009		M MESSAGE IDENTIFIER	M	
0065	an..6	M Message type identifier	M	ATHSTS = Authorisation status
0052	an..3	M Message type version number	M	D = Draft version/UN/EDIFACT Directory
0054	an..3	M Message type release number	M	97A = Release 1997 - A
0051	an..2	M Controlling agency	M	ED = EDIFICE (Electronic industries project)
0057	an..6	C Association assigned code	R	EDAS03 = Authorisation Status, Issue EDAS03
0068	an..35	C COMMON ACCESS REFERENCE	N	
S010		C STATUS OF THE TRANSFER	N	
0070	n..2	M Sequence message transfer number	N	
0073	a1	C First/last sequence message transfer indication	N	

**BGM BEGINNING OF MESSAGE**

Function: A segment uniquely identifying the message by means of its coded name, number and function.

Usage : M1

Notes :

Ref.	Rep.	Name		EDIFICE Utilisation
C002		C DOCUMENT/MESSAGE NAME	R	
1001	an..3	C Document/message name, coded	R	AST = Authorisation status (*) (*) EDIFICE code
1131	an..3	C Code list qualifier	N	
3055	an..3	C Code list responsible agency, coded	N	
1000	an..35	C Document/message name	N	
C106		C DOCUMENT/MESSAGE IDENTIFICATION	R	
1004	an..35	C Document/message number	R	Authorisation status number
1056	an..9	C Version	N	
1060	an..6	C Revision number	N	
1225	an..3	C MESSAGE FUNCTION, CODED	A	5 = Replace
4343	an..3	C RESPONSE TYPE, CODED	N	

**DTM DATE/TIME/PERIOD**

Function: A segment specifying the date/time of creation of the message.

Usage : R 1

Notes :

Ref.	Rep.	Name		EDIFICE Utilisation
C507		M DATE/TIME/PERIOD	M	
2005	an..3	M Date/time/period qualifier	M	137 = Document/message date/time Date when the document is created
2380	an..35	C Date/time/period	R	Authorisation status date
2379	an..3	C Date/time/period format qualifier	R	102 = CCYMMDD 203 = CCYMMDDHHMM 303 = CCYMMDDHHMMZZZ ZZZ = Time zone 304 = CCYMMDDHHMMSSZZZ ZZZ = Time zone X03 = CCYMMDDHHMMZZZZZ (*) ZZZZZ = Time zone X04 = CCYMMDDHHMMSSZZZZZ (*) ZZZZZ = Time zone (*) EDIFICE code



## NAD NAME AND ADDRESS

Function: A segment identifying the function and coded identification, name and address of a party involved.

Usage : R..2

Notes : It is advised that the party identification CO C082 be used. When CO C082 cannot be used it is recommended to use the structured name and address CO C080 through DE 3207 rather than the unstructured one CO C058.

The NAD segment that identifies the seller must be present.

Ref.	Rep.	Name		EDIFICE Utilisation
3035	an..3	M PARTY QUALIFIER	M	BY = Buyer SE = Seller
C082		C PARTY IDENTIFICATION DETAILS	A	
3039	an..35	M Party id. identification	M	
1131	an..3	C Code list qualifier	N	
3055	an..3	C Code list responsible agency, coded	R	9 = EAN (International Article Numbering association) 16 = DUNS (Dun & Bradstreet) 91 = Assigned by seller or seller's agent 92 = Assigned by buyer or buyer's agent
C058		C NAME AND ADDRESS	D	
3124	an..35	M Name and address line	M	
3124	an..35	C Name and address line	O	
3124	an..35	C Name and address line	O	
3124	an..35	C Name and address line	O	
3124	an..35	C Name and address line	O	
C080		C PARTY NAME	D	
3036	an..35	M Party name	M	
3036	an..35	C Party name	O	
3036	an..35	C Party name	O	
3036	an..35	C Party name	O	
3036	an..35	C Party name	O	
3036	an..35	C Party name	O	
3045	an..3	C Party name format, coded	N	
C059		C STREET	D	
3042	an..35	M Street and number/p.o. box	M	
3042	an..35	C Street and number/p.o. box	O	
3042	an..35	C Street and number/p.o. box	O	
3042	an..35	C Street and number/p.o. box	O	
3164	an..35	C CITY NAME	D	
3229	an..9	C COUNTRY SUB-ENTITY IDENTIFICATION	D	
3251	an..9	C POSTCODE IDENTIFICATION	D	
3207	an..3	C COUNTRY, CODED	D	Use ISO 3166, 2 alpha code

**SG1 DOC-DTM-NAD-RFF-CUX-SG2**

**DOC DOCUMENT/MESSAGE DETAILS**

Function: A segment specifying the authorisation number.

Usage : M1

Notes :

Ref.	Rep.	Name		EDIFICE Utilisation
C002		M DOCUMENT/MESSAGE NAME	M	173 = Authorisation to plan and ship orders Authorisation given by the seller to the buyer to ship goods to the end-customer and claim back the difference between the resale and new-buy price.  Authorisation number
1001	an..3	C Document/message name, coded	R	
1131	an..3	C Code list qualifier	N	
3055	an..3	C Code list responsible agency, coded	N	
1000	an..35	C Document/message name	N	
C503		C DOCUMENT/MESSAGE DETAILS	R	
1004	an..35	C Document/message number	R	
1373	an..3	C Document/message status, coded	N	
1366	an..35	C Document/message source	N	
3453	an..3	C Language, coded	N	
3153	an..3	C COMMUNICATION CHANNEL IDENTIFIER, CODED	N	
1220	n..2	C NUMBER OF COPIES OF DOCUMENT REQUIRED	N	
1218	n..2	C NUMBER OF ORIGINALS OF DOCUMENT REQUIRED	N	

**SG1      DOC-DTM-NAD-RFF-CUX-SG2**

**DTM      DATE/TIME/PERIOD**

Function: A segment specifying the date/time of creation of the authorisation and other dates/times relevant to the authorisation.

Usage : R..3

Notes : It is required to specify the date/time of creation of the authorisation.  
 If the expiry date is given at line item level, it must not appear here.

Ref.	Rep.	Name		EDIFICE Utilisation
C507		M DATE/TIME/PERIOD	M	
2005	an..3	M Date/time/period qualifier	M	36 = Expiry date 137 = Document/message date/time Date when the authorisation was created DLU = Date/time of last update (*) (*) EDIFICE code
2380	an..35	C Date/time/period	R	
2379	an..3	C Date/time/period format qualifier	R	102 = CCYYMMDD 203 = CCYYMMDDHHMM 303 = CCYYMMDDHHMMZZZ ZZZ = Time zone 304 = CCYYMMDDHHMMSSZZZ ZZZ = Time zone X03 = CCYYMMDDHHMMZZZZZ (*) ZZZZZ = Time zone X04 = CCYYMMDDHHMMSSZZZZZ (*) ZZZZZ = Time zone (*) EDIFICE code

**SG1 DOC-DTM-NAD-RFF-CUX-SG2**

**NAD NAME AND ADDRESS**

Function: A segment identifying the function and coded identification, name and address of the end-customer to whom the authorisation relates.

Usage : R 1

Notes : It is advised that the party identification CO C082 be used. When CO C082 cannot be used it is recommended to use the structured name and address CO C080 through DE 3207 rather than the unstructured one CO C058.

Ref.	Rep.	Name	EDIFICE Utilisation	
3035	an..3	M PARTY QUALIFIER	M	PC = Actual purchaser's customer  End-customer identification  9 = EAN (International Article Numbering association) 16 = DUNS (Dun & Bradstreet) 91 = Assigned by seller or seller's agent 92 = Assigned by buyer or buyer's agent
C082		C PARTY IDENTIFICATION DETAILS	A	
3039	an..35	M Party id. identification	M	
1131	an..3	C Code list qualifier	N	
3055	an..3	C Code list responsible agency, coded	R	
C058		C NAME AND ADDRESS	D	
3124	an..35	M Name and address line	M	
3124	an..35	C Name and address line	O	
3124	an..35	C Name and address line	O	
3124	an..35	C Name and address line	O	
C080		C PARTY NAME	D	
3036	an..35	M Party name	M	
3036	an..35	C Party name	O	
3036	an..35	C Party name	O	
3036	an..35	C Party name	O	
3036	an..35	C Party name	O	
3045	an..3	C Party name format, coded	N	
C059		C STREET	D	
3042	an..35	M Street and number/p.o. box	M	
3042	an..35	C Street and number/p.o. box	M	
3042	an..35	C Street and number/p.o. box	O	
3042	an..35	C Street and number/p.o. box	O	
3164	an..35	C CITY NAME	D	
3229	an..9	C COUNTRY SUB-ENTITY IDENTIFICATION	D	
3251	an..9	C POSTCODE IDENTIFICATION	D	
3207	an..3	C COUNTRY, CODED	D	Use ISO 3166, 2 alpha code

**SG1 DOC-DTM-NAD-RFF-CUX-SG2****RFF REFERENCE**

Function: A segment specifying the quote and/or request for quote number related to the authorisation.

Usage : 0..2

Notes :

Ref.	Rep.	Name		EDIFICE Utilisation
C506		M REFERENCE	M	AHU = Request for quote number Buyer's request for quote number PR = Price quote number
1153	an..3	M Reference qualifier	M	
1154	an..35	C Reference number	R	
1156	an..6	C Line number	N	
4000	an..35	C Reference version number	N	

**SG1 DOC-DTM-NAD-RFF-CUX-SG2**

**CUX CURRENCIES**

Function: A segment specifying a currency, valid for the whole authorisation.

Usage : R..2

Notes : A CUX segment specifying the order currency must be present.

Ref.	Rep.	Name		EDIFICE Utilisation
C504		C CURRENCY DETAILS	R	2 = Reference currency Use ISO 4217, 3 alpha code 4 = Invoicing currency Currency used between buyer and end-customer. This is the currency of the resale price. 9 = Order currency Currency used between buyer and seller. This is the currency of the buy price.
6347	an..3	M Currency details qualifier	M	
6345	an..3	C Currency, coded	R	
6343	an..3	C Currency qualifier	R	
6348	n..4	C Currency rate base	N	
C504		C CURRENCY DETAILS	N	
6347	an..3	M Currency details qualifier	N	
6345	an..3	C Currency, coded	N	
6343	an..3	C Currency qualifier	N	
6348	n..4	C Currency rate base	N	
5402	n..12	C RATE OF EXCHANGE	N	
6341	an..3	C CURRENCY MARKET EXCHANGE, CODED	N	

**SG2 LIN-PIA-RFF-DTM-QTY-PRI**
**LIN LINE ITEM**

Function: A segment identifying a line item by its item number, and agreed to be the primary reference number between the buyer and seller.  
 The segment also carries a sequence number assigned to the line item within the message, and the action taken.

Usage : M1

Notes :

Ref.	Rep.	Name		EDIFICE Utilisation
1082	an..6	C LINE ITEM NUMBER	R	It is required to assign a number to the line items within a message. The number is assigned by the sender of the message. The first line item within a message will be numbered 1 and further line items will be incremented by 1 for each new line. C = Closed (*) E = Expired (*) H = Hold (*) O = Open (*) (*) EDIFICE code  Primary reference BP = Buyer's part number DI = Distributor's part number (*) EN = International Article Numbering Association (EAN) MF = Manufacturer's (producer's) article number SRV = EAN.UCC Global Trade Item Number UP = UPC (Universal product code) VP = Vendor's (seller's) part number (*) EDIFICE code  9 = EAN (International Article Numbering association) 89 = Assigned by distributor 90 = Assigned by manufacturer 91 = Assigned by seller or seller's agent 92 = Assigned by buyer or buyer's agent 113 = US, UCC (Uniform Code Council)
1229	an..3	C ACTION REQUEST/NOTIFICATION, CODED	R	
C212		C ITEM NUMBER IDENTIFICATION	R	
7140	an..35	C Item number	R	
7143	an..3	C Item number type, coded	R	
1131	an..3	C Code list qualifier	N	
3055	an..3	C Code list responsible agency, coded	R	
C829		C SUB-LINE INFORMATION	N	
5495	an..3	C Sub-line indicator, coded	N	
1082	an..6	C Line item number	N	
1222	n..2	C CONFIGURATION LEVEL	N	
7083	an..3	C CONFIGURATION, CODED	N	

**SG2 LIN-PIA-RFF-DTM-QTY-PRI****PIA ADDITIONAL PRODUCT ID**

Function: A segment providing additional identification numbers for the line item.

Usage : D..7

Notes : The 5 internal repetitions of CO C212 may be used, but EDIFICE recommends to only use the first occurrence.

Ref.	Rep.	Name		EDIFICE Utilisation
4347	an..3	M PRODUCT ID. FUNCTION QUALIFIER	M	1 = Additional identification  BP = Buyer's part number CV = Customs article number DI = Distributor's part number (*) EN = International Article Numbering Association (EAN) MF = Manufacturer's (producer's) article number SRV = EAN.UCC Global Trade Item Number UP = UPC (Universal product code) VP = Vendor's (seller's) part number (* ) EDIFICE code
C212		M ITEM NUMBER IDENTIFICATION	M	
7140	an..35	C Item number	R	
7143	an..3	C Item number type, coded	R	
1131	an..3	C Code list qualifier	N	
3055	an..3	C Code list responsible agency, coded	R	
C212		C ITEM NUMBER IDENTIFICATION	O	
7140	an..35	C Item number	R	
7143	an..3	C Item number type, coded	R	
1131	an..3	C Code list qualifier	N	
3055	an..3	C Code list responsible agency, coded	R	9 = EAN (International Article Numbering association) 89 = Assigned by distributor 90 = Assigned by manufacturer 91 = Assigned by seller or seller's agent 92 = Assigned by buyer or buyer's agent 113 = US, UCC (Uniform Code Council)
C212		C ITEM NUMBER IDENTIFICATION	O	As for first CO C212
7140	an..35	C Item number	R	
7143	an..3	C Item number type, coded	R	
1131	an..3	C Code list qualifier	N	
3055	an..3	C Code list responsible agency, coded	R	
C212		C ITEM NUMBER IDENTIFICATION	O	As for first CO C212
7140	an..35	C Item number	R	
7143	an..3	C Item number type, coded	R	
1131	an..3	C Code list qualifier	N	
3055	an..3	C Code list responsible agency, coded	R	
C212		C ITEM NUMBER IDENTIFICATION	O	As for first CO C212
7140	an..35	C Item number	R	
7143	an..3	C Item number type, coded	R	
1131	an..3	C Code list qualifier	N	
3055	an..3	C Code list responsible agency, coded	R	



**SG2 LIN-PIA-RFF-DTM-QTY-PRI****RFF REFERENCE**

Function: A segment specifying the authorisation line number.

Usage : R 1

Notes :

Ref.	Rep.	Name		EDIFICE Utilisation
C506		M REFERENCE	M	
1153	an..3	M Reference qualifier	M	LI = Line item reference number
1154	an..35	C Reference number	N	
1156	an..6	C Line number	R	Authorisation line number
4000	an..35	C Reference version number	N	

**SG2 LIN-PIA-RFF-DTM-QTY-PRI**

**DTM DATE/TIME/PERIOD**

Function: A segment specifying the expiry date/time, and other dates/times relevant to the line item.

Usage : D..3

Notes : If the expiry date/time is given at document level, it should not appear here.

Ref.	Rep.	Name	EDIFICE Utilisation	
C507		M DATE/TIME/PERIOD	M	
2005	an..3	M Date/time/period qualifier	M	
2380	an..35	C Date/time/period	R	
2379	an..3	C Date/time/period format qualifier	R	

36 = Expiry date  
 206 = End date/time  
 Date that the authorisation line item was closed  
 DLU = Date of last update (\*)  
 (\*) EDIFICE code

102 = CCYYMMDD  
 203 = CCYYMMDDHHMM  
 303 = CCYYMMDDHHMMZZZ  
 ZZZ = Time zone  
 304 = CCYYMMDDHHMMSSZZZ  
 ZZZ = Time zone  
 X03 = CCYYMMDDHHMMZZZZZ (\*)  
 ZZZZZ = Time zone  
 X04 = CCYYMMDDHHMMSSZZZZZ (\*)  
 ZZZZZ = Time zone  
 (\*) EDIFICE code

**SG2 LIN-PIA-RFF-DTM-QTY-PRI**

**QTY QUANTITY**

Function: A segment specifying the quantity related to the line item.  
 Usage : R..3  
 Notes : EDIFICE recommends to always specify the quantity authorised.  
 The quantity balance to ship only needs to be specified if non-zero.

Ref.	Rep.	Name	EDIFICE Utilisation
C186		M QUANTITY DETAILS	M
6063	an..3	M Quantity qualifier	M
6060	n..15	M Quantity	M
6411	an..3	C Measure unit qualifier	R

QAU = Quantity authorised (\*)  
 QBS = Quantity balance to ship (\*)  
 QCL = Quantity claimed (\*)  
 (\*) EDIFICE code

Use the following codes from UN/ECE Recommendation no.20, Codes for Units of Measurement:

- CLT = centilitre
- CMT = centimetre
- GRM = gram
- KGM = kilogram
- KMT = kilometre (\*)
- LTR = litre
- MGM = milligram
- MMT = millimetre
- MTK = square metre
- MTQ = cubic metre
- MTR = metre
- PCE = piece (\*)

(\*) EDIFICE code, not included in UN/ECE Recommendation No.20  
 Other codes should be previously agreed between trading partners.

**SG2 LIN-PIA-RFF-DTM-QTY-PRI**

**PRI PRICE DETAILS**

Function: A segment specifying the line item price and qualifying information.

Usage : 0..3

Notes : Catalogue price and new buy price are specified with the order currency.  
Resale price is specified with the invoicing currency.

Ref.	Rep.	Name		EDIFICE Utilisation
C509		C PRICE INFORMATION	R	
5125	an..3	M Price qualifier	M	AAA = Calculation net
5118	n..15	C Price	R	
5375	an..3	C Price type, coded	R	CA = Catalogue Stocking price used between the buyer and seller. NBP = New buy price (*) Re-negotiated buy price between the buyer and seller. RES = Resale price (*) Price used between the buyer and the end-customer. (*) EDIFICE code
5387	an..3	C Price type qualifier	N	
5284	n..9	C Unit price basis	R	
6411	an..3	C Measure unit qualifier	R	Use the following codes from UN/ECE Recommendation no.20, Codes for Units of Measurement: CLT = centilitre CMT = centimetre GRM = gram KGM = kilogram KMT = kilometre (*) LTR = litre MGM = milligram MMT = millimetre MTK = square metre MTQ = cubic metre MTR = metre PCE = piece (*) (*) EDIFICE code, not included in UN/ECE Recommendation No. 20 Other codes should be previously agreed between trading partners.
5213	an..3	C SUB-LINE PRICE CHANGE, CODED	N	

**UNT MESSAGE TRAILER**

Function: A service segment ending, and providing information for checking the completeness of a message.

Usage : M1

Notes : Refer to EDIFICE Utilisation of the UN/EDIFACT Service Segments, Issue EDSS04.

Ref.	Rep.	Name	EDIFICE Utilisation	
0074	n..6	M NUMBER OF SEGMENTS IN A MESSAGE	M	Count of all segments in the message, UNH and UNT included.
0062	an..14	M MESSAGE REFERENCE NUMBER	M	Must be the same reference number as in DE 0062 of the UNH segment of this message.

## **EXAMPLES**

An authorisation status message containing one authorisation with two line items.  
Both have an open status.

```
UNB+UNOC:3+X:1:X+X:1:X+021209:1520+66+X:AA+ATHSTS+A+1+X+1'  
UNH+1+ATHSTS:D:97A:ED:EDAS03'  
BGM+AST+ATHSTATUSNUMBER1+5'  
DTM+137:20000428:102'  
NAD+SE+SELLERCODE:::91'  
DOC+173+BX10092089'  
DTM+137:20000304:102'  
NAD+PC+999999999:::91'  
RFF+PR:QUOTENUM1'  
CUX+2:USD:9'  
LIN+1+O+VENPAR:VP:::91'  
RFF+LI:::1'  
DTM+36:20001028:102'  
QTY+QAU:1000:PCE'  
QTY+QCL:800:PCE'  
QTY+QBS:200:PCE'  
PRI+AAA:1:CA:::1:PCE'  
PRI+AAA:0.8:NBP:::1:PCE'  
LIN+2+O+VENPAR2:VP:::91'  
RFF+LI:::2'  
DTM+36:20001028:102'  
QTY+QAU:2000:PCE'  
QTY+QCL:800:PCE'  
QTY+QBS:1200:PCE'  
PRI+AAA:15:CA:::1:PCE'  
PRI+AAA:12:NBP:::1:PCE'  
UNT+26+1'  
UNZ+1+66'
```