



## **EDIFICE Message Implementation Guideline**

### **Blanket Purchase Order**

### **ORDERS Issue EDBO03**

**Endorsed 27 November 2002**

**Based on UN/EDIFACT D.97A ORDERS Message**

Copyright ©EDIFICE 2004

All rights reserved. No part of this publication may be reproduced or transmitted in any form or by any means without prior permission of EDIFICE.

Notwithstanding the fact that the utmost care has been observed in the collecting, drawing up and formulating of data, EDIFICE can under no circumstances be held liable for errors, omissions or misinterpretations as a result of the information compiled in the guidelines.

EDIFICE  
The European B2B Forum for the Electronics Industry  
EDIFICE secretariat  
Dora Cresens  
Tiensestraat 2  
B-3320 Hoegaarden  
Belgium  
Tel: +32 16 76 54 40  
Fax: +32 16 76 53 58  
Email: Dora.Cresens@edifice.org

## **TABLE OF CONTENTS**

<u>TITLE</u>	<u>PAGE</u>
COMPARISON TO PREVIOUS ISSUE	3
EDIFICE FUNCTIONAL DEFINITION	5
REFERENCES	6
EXPLANATORY NOTES	6
MESSAGE STRUCTURE CHART	8
BRANCHING DIAGRAM	9
SEGMENT GROUPS/SEGMENTS DESCRIPTION	10
UNH           MESSAGE HEADER	14
BGM           BEGINNING OF MESSAGE	15
DTM           DATE/TIME/PERIOD	16
SG1 - RFF     REFERENCE	17
SG1 - DTM     DATE/TIME/PERIOD	18
SG2 - NAD     NAME AND ADDRESS	19
SG3 - RFF     REFERENCE	20
SG5 - CTA     CONTACT INFORMATION	21
SG5 - COM     COMMUNICATION CONTACT	22
SG6 - TAX     DUTY/TAX/FEE DETAILS	23
SG7 - CUX     CURRENCIES	24
SG28 - LIN    LINE ITEM	25
SG28 - PIA    ADDITIONAL PRODUCT ID	26
SG28 - IMD    ITEM DESCRIPTION	27
SG28 - QTY    QUANTITY	28
SG28 - ALI    ADDITIONAL INFORMATION	29
SG32 - PRI    PRICE DETAILS	30
SG33 - RFF    REFERENCE	31
SG33 - DTM    DATE/TIME/PERIOD	32
SG34 - PAC    PACKAGE	33
SG34 - QTY    QUANTITY	35
SG38 - TAX    DUTY/TAX/FEE DETAILS	36
SG39 - NAD    NAME AND ADDRESS	37
UNS           SECTION CONTROL	38
UNT           MESSAGE TRAILER	39
EXAMPLES	40 - 42

## **COMPARISON TO PREVIOUS ISSUE**

12 May 2004 : EDIFIX 5.0 Technical Upgrade

- The 'KMT' qualifier in SEG QTY and PRI DE 6411 is now defined as (\*) EDIFICE code. UN/ECE Recommendation 20 specifies 'KTM' as qualifier for 'kilometre'.

03 November 2003 : Correction of SG Structure. This change does not affect the functionality of the message, it only affects the documentation.

SG28 LIN-PIA-IMD-QTY-ALI-**FTX**-SG32-SG33-SG34-SG38-SG39 - Changed to SG28 LIN-PIA-IMD-QTY-ALI-SG32-SG33-SG34-SG38-SG39

21 May 2003: EDIFIX 4.2 Technical upgrade; review and correction of examples

Issue EDBO03 of 13 November 2002 is based on UN/EDIFACT D97.A / Code List D01.A

- Addition of the following code value:

SG28, LIN segment, CO C212, DE 7143 codes 'SRV' EAN.UCC Global Trade Item Number

SG28, PIA segment, CO C212, DE 7143 codes 'SRV' EAN.UCC Global Trade Item Number

Issue EDBO02; Publication date 29 May 2002 – addition of recommended set of DTM qualifiers

Issue EDBO02 includes the changes that have been made to the issue 1 of the Blanket Order document endorsed by the EDIFICE Plenary on 6 September 1993. The changes are as follows:

- Recast from the 92.1 version of the UN/EDIFACT directory to the D.97A version,

- Addition of the following code values:

SG1, RFF segment, DE 1153, code 'GC' Government contract number

SG2, NAD segment, DE 3035, code 'AK' Acknowledgement recipient

SG2, NAD segment, DE 3055, code '16' DUNS (Dun & Bradstreet)

SG5, COM segment, DE 3155, code 'EM' Electronic mail

SG28, LIN segment, DE 7143, codes 'DI' Distributor's part number

'MF' Manufacturer's (producer's) article number and

'UP' UPC (Universal product code)

SG28, LIN segment, DE 3055, codes '89' Assigned by distributor

'90' Assigned by manufacturer and

'113' US, UCC (Uniform Code Council)

SG28, PIA segment, DE 7143, codes 'AA' Product version number

'CL' Color number

'DI' Distributor's part number

'MF' Manufacturer's (producer's) article number

'MN' Model number

'SN' Serial number and

'UP' UPC (Universal product code)

SG28, PIA segment, DE 3055, codes '89' Assigned by distributor

'90' Assigned by manufacturer and

'113' US, UCC (Uniform Code Council)

SG28, IMD segment, DE 7081, code '26' Ship to line

SG32, PRI segment, DE 5375, code 'DI' Distributor

SG33, RFF segment, DE 1153, code 'GC' Government contract number

SG34, PAC segment, CO C202, DE 3055, code '116' US, ANSI ASC X12,

- Addition of the following segment groups/segment:

SG1, DTM segment

SG3

SG33, DTM segment

SG34, QTY segment

SG38

SG39,

- Replacement of the following codes:

SG6, TAX segment, DE 5283, code '9' to '7' Tax

SG32, PRI segment, CO C509, DE 5125, code 'CAL' to 'AAA' Calculation net,

- Deletion of the following code values:

SG5, COM segment, DE 3155, code 'TL' Telex

SG28, PIA segment, DE 7143, code 'CCM' COCOM list number,

- Usage changed for the following segment groups/segments/data elements:

BGM segment, DE 1225, X to A

SG1, D..2 to A..3

SG2, R..5 to R..6

SG5, COM segment, R..3 to O..3

SG5, CTA segment, CO C056, DE 3412, A to D

SG6, TAX segment, CO C243, X to D  
SG6, TAX segment, DE 5305, X to R  
SG6, TAX segment, DE 3446, R to X  
SG28, R..200000 to R..9999  
SG28, PIA segment, D..12 to D..10  
SG28, IMD segment, DE 7077, X to D  
SG28, IMD segment, DE 7081, R to O  
SG28, IMD segment, CO C273, X to D  
SG33, R..4 to R..5  
SG34, PAC segment, CO C202, DE 3055, X to D,

- Where UN/ECE Recommendations are referenced the most commonly used codes have been identified,
- Alignment of segments and composite data elements to ensure conformance (data harmonization) across all EDIFICE Implementation Guidelines,
- Update of the REFERENCES and EXPLANATORY NOTES section to comply with the EDIFICE Standards for Documentation of Message Implementation Guidelines issue 3,
- Update of examples,
- Documentation adjustments resulting from the use of GEFEG's EdiFix Message Implementation Guidelines documentation tool,
- Correction of typographical errors.

## **EDIFICE FUNCTIONAL DEFINITION**

The Blanket Order is part of a business cycle which includes forecast, and call-off activities. It will normally be used where trading partners have a stable trading environment, and multiple deliveries of stable product requirements exist. The Blanket Order will order goods over an extended time period but where requirements such as schedules and locations for delivery are not known. This information should be transmitted using Forecast/Call-Off (DELFOR) or JIT-Delivery (DELJIT) messages, or by non-EDI means or by a combination of these.

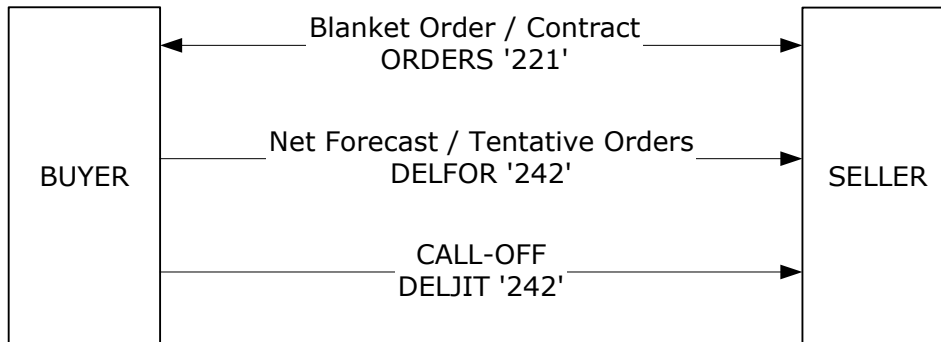

It should be noted that the Blanket Order is a specific implementation of the UN/EDIFACT ORDERS message.

The Blanket Order establishes the procurement relationship between the trading partners, allowing them to implement the forecast and call-off activity and to carry out payment cycle activities by providing the order number.

Trading partners must agree the point of commitment to purchase specific quantities of products prior to using a Blanket Order. The point of commitment may be at the Blanket Order stage, or it may be later in the business cycle, for example a defined number of weeks prior to delivery, which would be communicated in the Forecast/Call-Off (DELFOR) message.

The Blanket Order can be used in three different ways:

1. For ordering parts for delivery over a defined extended period of time (e.g. 1 year). The Blanket Order ceases to be effective at the end of the time period. The Blanket Order must at least contain statements of the description and time period of the order. Where possible the price should be contained within the message.
2. For ordering a defined quantity of product for delivery over an undefined extended time period (e.g. 100,000 pieces estimated as 2 years requirement). The Blanket Order ceases to be effective when the 100,000 pieces are delivered. The Blanket Order must at least contain statements of the description and the quantity of goods to be ordered. Where possible the price should be contained within the message.
3. For ordering a defined quantity of product for delivery over a defined time period (e.g. 100,000 pieces within 1 year). The defined quantity must be delivered within the time period. The Blanket Order contains the information required in both Use 1 and Use 2 above.

The Blanket Order may contain one or multiple line items.

The EDIFICE implementation guideline for the utilisation of the EDIFACT ORDERS message assumes that a business agreement exists, which defines all standard, basic trading terms and conditions as agreed between the two parties. As such a Blanket Order always constitutes a business transaction under this agreement, to which it will refer for basic terms and conditions.

The following additional principles apply:

- All Blanket Orders should have a unique document number assigned by the buyer and this must be sent in the BGM segment.
- The buyer's and seller's identification must always be present in the message, and this information must be sent in the NAD segment.
- One item number (Product Number) agreed to be the primary reference number between the buyer and the seller should be used to identify the item being ordered. Only if a service is ordered for which no code identification exists, may the primary reference be replaced by an item description.
- Data at detail level will not override data at header level.

## **REFERENCES**

Refer to the document : Reference list for the EDIFICE message guidelines – Issue 1

## **EXPLANATORY NOTES**

Refer to the document : Explanatory notes for the EDIFICE message guidelines – Issue 1

## MESSAGE STRUCTURE CHART

UNH	MESSAGE HEADER	M1
BGM	BEGINNING OF MESSAGE	M1
DTM	DATE/TIME/PERIOD	M..3
—SG1		A..3
—RFF	REFERENCE	M1
—DTM	DATE/TIME/PERIOD	D1
—SG2		R..6
—NAD	NAME AND ADDRESS	M1
—SG3		D..2
—RFF	REFERENCE	M1
—SG5		O..2
—CTA	CONTACT INFORMATION	M1
—COM	COMMUNICATION CONTACT	O..3
—SG6		D1
—TAX	DUTY/TAX/FEE DETAILS	M1
—SG7		D1
—CUX	CURRENCIES	M1
—SG28		R..9999
—LIN	LINE ITEM	M1
—PIA	ADDITIONAL PRODUCT ID	D..10
—IMD	ITEM DESCRIPTION	D1
—QTY	QUANTITY	D1
—ALI	ADDITIONAL INFORMATION	O1
—SG32		A1
—PRI	PRICE DETAILS	M1
—SG33		R..5
—RFF	REFERENCE	M1
—DTM	DATE/TIME/PERIOD	D1
—SG34		D1
—PAC	PACKAGE	M1
—QTY	QUANTITY	O1
—SG38		D1
—TAX	DUTY/TAX/FEE DETAILS	M1
—SG39		O1
—NAD	NAME AND ADDRESS	M1
—UNS	SECTION CONTROL	M1
—UNT	MESSAGE TRAILER	M1

# BRANCHING DIAGRAM

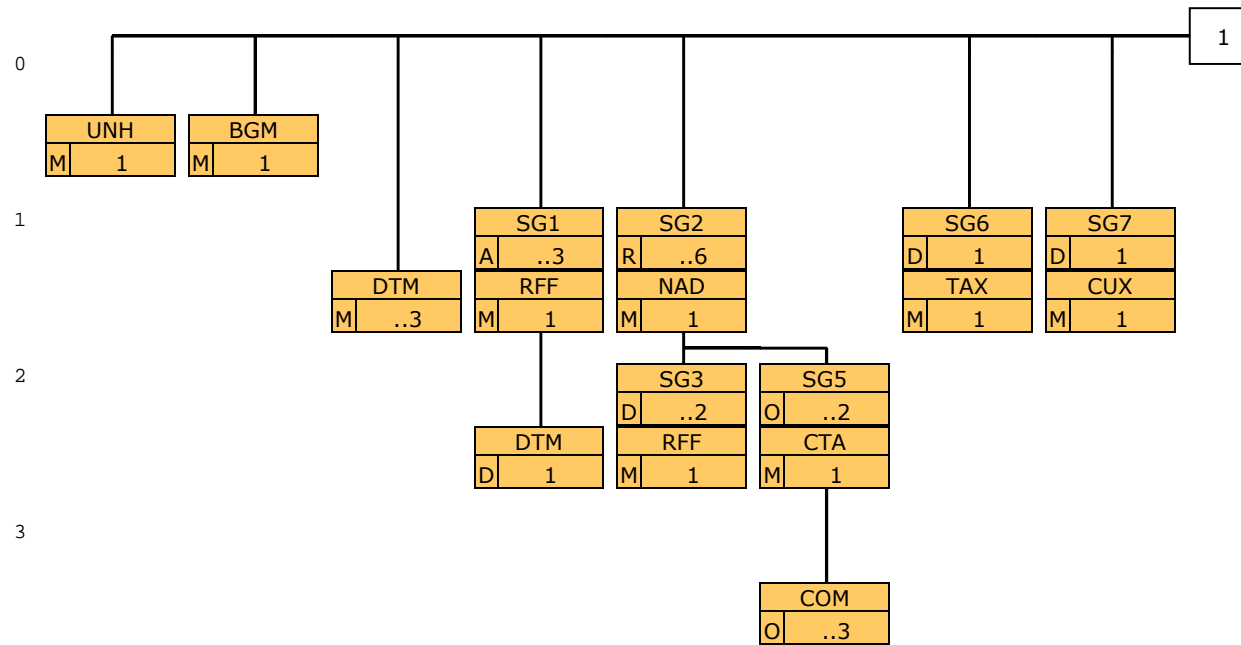



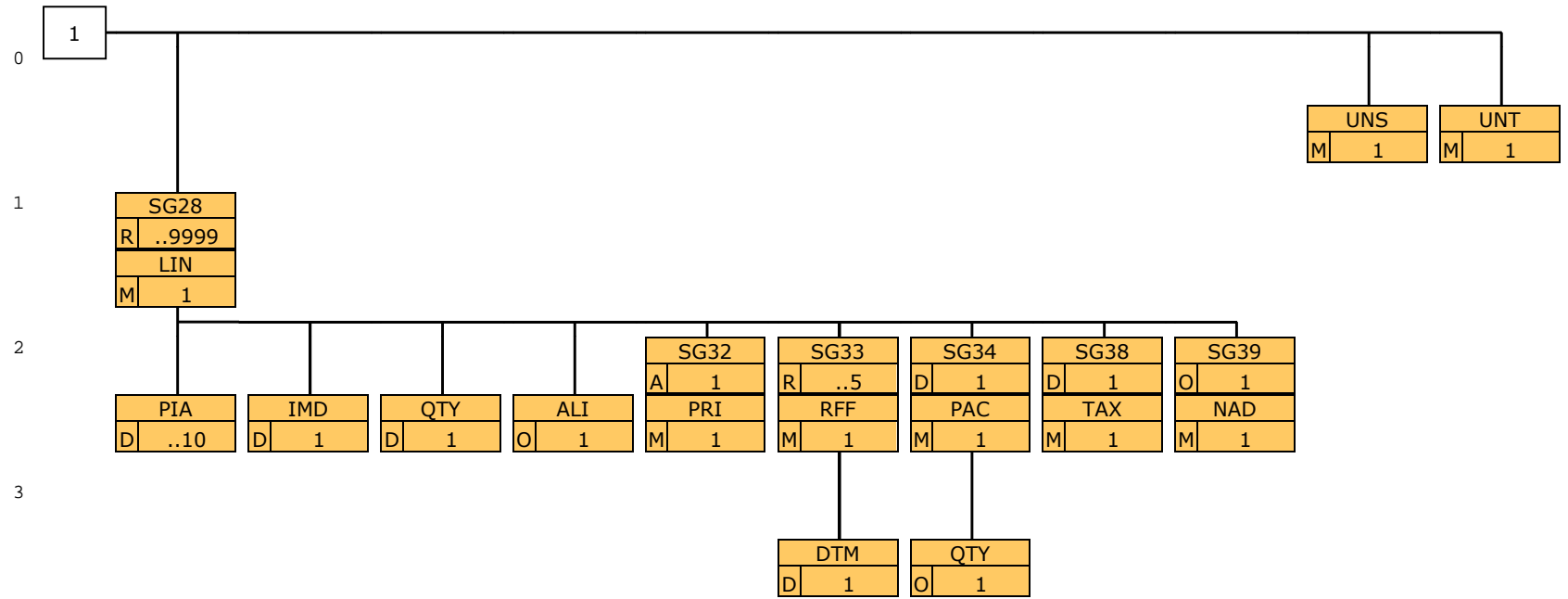

## **SEGMENT GROUPS/SEGMENTS DESCRIPTION**

### **UNH MESSAGE HEADER**

---

Function: A service segment heading, and uniquely identifying the message.  
Usage : M1

### **BGM BEGINNING OF MESSAGE**

---

Function: A segment uniquely identifying the message by means of its coded name, number and function.  
Usage : M1

### **DTM DATE/TIME/PERIOD**

---

Function: A segment specifying the date of creation of the message and, other dates relevant to the whole message.  
Usage : M..3

### **SG1 RFF-DTM**

---

Function: A group of segments referencing documents and their dates, relating to the whole message.  
Usage : A..3  
Notes : One RFF segment specifying contract or quote information should be present, preferably at header level. If this information is given at detail level, it must not appear here.  
The DTM segment must be sent where local law requires the date of a reference document to be sent.

### **RFF REFERENCE**

---

Function: A segment specifying a document reference number.  
Usage : M1

### **DTM DATE/TIME/PERIOD**

---

Function: A segment specifying the date of the reference document.  
Usage : D1

### **SG2 NAD-SG3-SG5**

---

Function: A group of segments identifying the parties involved and their associated information, relevant to the whole message.  
Usage : R..6  
Notes : The NAD segments that identify the buyer and seller must be present.  
SG3 is used if EC regulations and/or country law requires reference numbers to be sent.

### **NAD NAME AND ADDRESS**

---

Function: A segment identifying the function and coded identification, name and address of a party involved.  
Usage : M1

### **SG3 RFF**

---

Function: A group of segments giving references relating to the identified buying party involved.  
Usage : D..2  
Notes :

### **RFF REFERENCE**

---

Function: A segment specifying a company specific reference.  
Usage : M1

### **SG5 CTA-COM**

---

Function: A group of segments giving contact details of the specific person or department within the identified buying party involved, to whom communication should be directed.  
Usage : O..2

Notes : This segment group will only be used under the NAD identifying the buyer.

---

**CTA CONTACT INFORMATION**

---

Function: A segment identifying a person or department, and their function.  
Usage : M1

---

**COM COMMUNICATION CONTACT**

---

Function: A segment identifying a communications type and number.  
Usage : O..3

---

**SG6 TAX**

---

Function: A group of segments specifying tax related information, applicable to the whole message.  
Usage : D1  
Notes : Used if country law requires tax to be specified.

---

**TAX DUTY/TAX/FEE DETAILS**

---

Function: A segment specifying Value Added Tax, category and rate.  
Usage : M1

---

**SG7 CUX**

---

Function: A group of segments specifying the currency, valid for the whole message.  
Usage : D1  
Notes : The currency must be specified if prices and/or amounts are sent.

---

**CUX CURRENCIES**

---

Function: A segment specifying the order currency for all prices and/or amounts.  
Usage : M1

---

**SG28 LIN-PIA-IMD-QTY-ALI-SG32-SG33-SG34-SG38-SG39**

---

Function: A group of segments providing ordering details of the individual line items i.e. ordered products for delivery or services.  
Usage : R..9999  
Notes : The PIA segment is dependent on whether the primary reference to the line item being ordered is insufficient to identify the item.  
The IMD segment is used to provide an additional description of the primary reference to the line item being ordered. It may also be used for items that can not be identified by a code or article number.  
The QTY segment is used if a definite quantity for delivery needs to be specified.  
SG34 is used to specify any alternative packaging methods which have been agreed between trading partners.  
SG38 is used if country law requires tax to be specified.

---

**LIN LINE ITEM**

---

Function: A segment identifying a line item by its item number, and agreed to be the primary reference number between the buyer and seller.  
The segment also carries a sequence number assigned to the line item within the message.  
Usage : M1

---

**PIA ADDITIONAL PRODUCT ID**

---

Function: A segment providing additional identification numbers for the line item.  
Usage : D..10

---

**IMD ITEM DESCRIPTION**

---

Function: A segment specifying ship to stock or ship to line quality and/or an additional description in clear or coded form, for the line item.  
Usage : D1

---

**QTY QUANTITY**

---

Function: A segment specifying the total quantity for delivery for the line item.  
Usage : D1

---

**ALI ADDITIONAL INFORMATION**

---

Function: A segment indicating the country of origin for the line item.  
Usage : O1

---

**SG32 PRI**

---

Function: A group of segments specifying pricing information for the line item.  
Usage : A1  
Notes :

---

**PRI PRICE DETAILS**

---

Function: A segment specifying the line item price and the qualifying information.  
Usage : M1

---

**SG33 RFF-DTM**

---

Function: A group of segments specifying references for the line item.  
Usage : R..5  
Notes : The DTM segment must be sent where local law requires the date of a reference document to be sent.

---

**RFF REFERENCE**

---

Function: A segment specifying the line item reference number as given by the buyer, or a document reference number.  
Usage : M1

---

**DTM DATE/TIME/PERIOD**

---

Function: A segment specifying the date of the reference document.  
Usage : D1

---

**SG34 PAC-QTY**

---

Function: A group of segments specifying product packaging information.  
Usage : D1  
Notes :

---

**PAC PACKAGE**

---

Function: A segment specifying the product package type.  
Usage : M1

---

**QTY QUANTITY**

---

Function: A segment specifying the number of products contained in the package type.  
Usage : O1

---

**SG38 TAX**

---

Function: A group of segments specifying tax related information for the line item.  
Usage : D1  
Notes :

---

**TAX DUTY/TAX/FEE DETAILS**

---

Function: A segment specifying Value Added Tax, category and rate for the line item.  
Usage : M1

**SG39 NAD**

---

Function: A group of segments identifying the parties involved and their associated information,  
for the line item.  
Usage : O1  
Notes : SG41 is only used when DE 3035 in NAD = 'BY'.

**NAD NAME AND ADDRESS**

---

Function: A segment identifying the manufacturer's code, for the line item.  
Usage : M1

**UNS SECTION CONTROL**

---

Function: A service segment separating detail and summary section.  
Usage : M1

**UNT MESSAGE TRAILER**

---

Function: A service segment ending, and providing information for checking the completeness of a  
message.  
Usage : M1

## SEGMENT DETAILS



### **UNH MESSAGE HEADER**

Function: A service segment heading, and uniquely identifying the message.

Usage : M1

Notes : Refer to EDIFICE Utilisation of the UN/EDIFACT Service Segments, Issue EDSS04

Ref.	Rep.	Name		EDIFICE Utilisation
0062	an..14	M MESSAGE REFERENCE NUMBER	M	Transmission message count from 1
S009		M MESSAGE IDENTIFIER	M	
0065	an..6	M Message type identifier	M	ORDERS = Purchase order message
0052	an..3	M Message type version number	M	D = Draft version/UN/EDIFACT Directory
0054	an..3	M Message type release number	M	97A = Release 1997 - A
0051	an..2	M Controlling agency	M	UN = UN/CEFACT
0057	an..6	C Association assigned code	R	EDBO03 = Blanket Order Issue EDBO03
0068	an..35	C COMMON ACCESS REFERENCE	N	
S010		C STATUS OF THE TRANSFER	N	
0070	n..2	M Sequence message transfer number	N	
0073	a1	C First/last sequence message transfer indication	N	

**BGM BEGINNING OF MESSAGE**

Function: A segment uniquely identifying the message by means of its coded name, number and function.

Usage : M1

Notes :

Ref.	Rep.	Name		EDIFICE Utilisation
C002		C DOCUMENT/MESSAGE NAME	R	
1001	an..3	C Document/message name, coded	R	221 = Blanket order
1131	an..3	C Code list qualifier	N	
3055	an..3	C Code list responsible agency, coded	N	
1000	an..35	C Document/message name	N	
C106		C DOCUMENT/MESSAGE IDENTIFICATION	R	
1004	an..35	C Document/message number	R	Blanket order number
1056	an..9	C Version	N	
1060	an..6	C Revision number	N	
1225	an..3	C MESSAGE FUNCTION, CODED	A	9 = Original
4343	an..3	C RESPONSE TYPE, CODED	N	

**DTM DATE/TIME/PERIOD**

Function: A segment specifying the date of creation of the message and, other dates relevant to the whole message.

Usage : M..3

Notes : It is required to specify the date of creation of the message.

Ref.	Rep.	Name	EDIFICE Utilisation	
C507		M DATE/TIME/PERIOD	M	
2005	an..3	M Date/time/period qualifier	M	137 = Document/message date/time Date when the document is created 158 = Horizon start date 159 = Horizon end date
2380	an..35	C Date/time/period	R	
2379	an..3	C Date/time/period format qualifier	R	102 = CCYYMMDD 203 = CCYYMMDDHHMM 303 = CCYYMMDDHHMMZZZ ZZZ = Time zone 304 = CCYYMMDDHHMMSSZZZ ZZZ = Time zone X03 = CCYYMMDDHHMMZZZZZ (*) ZZZZ = Time zone X04 = CCYYMMDDHHMMSSZZZZZ (*) ZZZZ = Time zone (*) EDIFICE code



**SG1 RFF-DTM****RFF REFERENCE**

Function: A segment specifying a document reference number.

Usage : M1

Notes :

Ref.	Rep.	Name		EDIFICE Utilisation
C506		M REFERENCE	M	AAD = Contract addendum number CT = Contract number GC = Government contract number PR = Price quote number
1153	an..3	M Reference qualifier	M	
1154	an..35	C Reference number	R	
1156	an..6	C Line number	N	
4000	an..35	C Reference version number	N	

**SG1 RFF-DTM**

**DTM DATE/TIME/PERIOD**

Function: A segment specifying the date of the reference document.

Usage : D 1

Notes :

Ref.	Rep.	Name		EDIFICE Utilisation
C507		M DATE/TIME/PERIOD	M	
2005	an..3	M Date/time/period qualifier	M	171 = Reference date/time
2380	an..35	C Date/time/period	R	
2379	an..3	C Date/time/period format qualifier	R	102 = CCYYMMDD 203 = CCYYMMDDHHMM 303 = CCYYMMDDHHMMZZZ ZZZ = Time zone 304 = CCYYMMDDHHMMSSZZZ ZZZ = Time zone X03 = CCYYMMDDHHMMZZZZZ (*) ZZZZZ = Time zone X04 = CCYYMMDDHHMMSSZZZZZ (*) ZZZZZ = Time zone (*) EDIFICE code

**SG2 NAD-SG3-SG5**

**NAD NAME AND ADDRESS**

Function: A segment identifying the function and coded identification, name and address of a party involved.

Usage : M1

Notes : It is advised that the party identification CO C082 be used. When CO C082 cannot be used it is recommended to use the structured name and address CO C080 through DE 3207 rather than the unstructured one CO C058.

Ref.	Rep.	Name		EDIFICE Utilisation
3035	an..3	M PARTY QUALIFIER	M	AK = Acknowledgement recipient BY = Buyer DP = Delivery party FW = Freight forwarder IV = Invoicee SE = Seller
C082		C PARTY IDENTIFICATION DETAILS	A	
3039	an..35	M Party id. identification	M	
1131	an..3	C Code list qualifier	N	
3055	an..3	C Code list responsible agency, coded	R	9 = EAN (International Article Numbering association) 16 = DUNS (Dun & Bradstreet) 91 = Assigned by seller or seller's agent 92 = Assigned by buyer or buyer's agent
C058		C NAME AND ADDRESS	D	
3124	an..35	M Name and address line	M	
3124	an..35	C Name and address line	O	
3124	an..35	C Name and address line	O	
3124	an..35	C Name and address line	O	
3124	an..35	C Name and address line	O	
C080		C PARTY NAME	D	
3036	an..35	M Party name	M	
3036	an..35	C Party name	O	
3036	an..35	C Party name	O	
3036	an..35	C Party name	O	
3036	an..35	C Party name	O	
3045	an..3	C Party name format, coded	N	
C059		C STREET	D	
3042	an..35	M Street and number/p.o. box	M	
3042	an..35	C Street and number/p.o. box	O	
3042	an..35	C Street and number/p.o. box	O	
3042	an..35	C Street and number/p.o. box	O	
3164	an..35	C CITY NAME	D	
3229	an..9	C COUNTRY SUB-ENTITY IDENTIFICATION	D	
3251	an..9	C POSTCODE IDENTIFICATION	D	
3207	an..3	C COUNTRY, CODED	D	Use ISO 3166, 2 alpha code

**SG3 RFF****RFF REFERENCE**

Function: A segment specifying a company specific reference.

Usage : M1

Notes :

Ref.	Rep.	Name		EDIFICE Utilisation
C506		M REFERENCE	M	VA = VAT registration number GN = Government reference number
1153	an..3	M Reference qualifier	M	
1154	an..35	C Reference number	R	
1156	an..6	C Line number	N	
4000	an..35	C Reference version number	N	

**SG5 CTA-COM****CTA CONTACT INFORMATION**

Function: A segment identifying a person or department, and their function.

Usage : M1

Notes :

Ref.	Rep.	Name	EDIFICE Utilisation	
3139	an..3	C CONTACT FUNCTION, CODED	R	PD = Purchasing contact SC = Schedule contact If a code is available use DE 3413, otherwise use DE 3412.
C056		C DEPARTMENT OR EMPLOYEE DETAILS	R	
3413	an..17	C Department or employee identification	D	
3412	an..35	C Department or employee	D	

**SG5 CTA-COM**

---

**COM COMMUNICATION CONTACT**

---

Function: A segment identifying a communications type and number.

Usage : 0..3

Notes :

Ref.	Rep.	Name		EDIFICE Utilisation
C076		M COMMUNICATION CONTACT	M	
3148	an..512	M Communication number	M	
3155	an..3	M Communication channel qualifier	M	EM = Electronic mail FX = Telefax TE = Telephone

**SG6 TAX**

**TAX DUTY/TAX/FEE DETAILS**

Function: A segment specifying Value Added Tax, category and rate.

Usage : M1

Notes : CO C243 is not used when DE 5305 = 'E'.

Ref.	Rep.	Name		EDIFICE Utilisation
5283	an..3	M DUTY/TAX/FEE FUNCTION QUALIFIER	M	7 = Tax
C241		C DUTY/TAX/FEE TYPE	R	
5153	an..3	C Duty/tax/fee type, coded	R	VAT = Value added tax
1131	an..3	C Code list qualifier	N	
3055	an..3	C Code list responsible agency, coded	N	
5152	an..35	C Duty/tax/fee type	N	
C533		C DUTY/TAX/FEE ACCOUNT DETAIL	N	
5289	an..6	M Duty/tax/fee account identification	N	
1131	an..3	C Code list qualifier	N	
3055	an..3	C Code list responsible agency, coded	N	
5286	an..15	C DUTY/TAX/FEE ASSESSMENT BASIS	N	
C243		C DUTY/TAX/FEE DETAIL	D	
5279	an..7	C Duty/tax/fee rate identification	N	
1131	an..3	C Code list qualifier	N	
3055	an..3	C Code list responsible agency, coded	N	
5278	an..17	C Duty/tax/fee rate	R	Tax rate
5273	an..12	C Duty/tax/fee rate basis identification	N	
1131	an..3	C Code list qualifier	N	
3055	an..3	C Code list responsible agency, coded	N	
5305	an..3	C DUTY/TAX/FEE CATEGORY, CODED	R	AA = Lower rate VAT at a lower rate than standard rate E = Exempt from tax S = Standard rate Z = Zero rated goods
3446	an..20	C PARTY TAX IDENTIFICATION NUMBER	N	

**SG7 CUX**

**CUX CURRENCIES**

Function: A segment specifying the order currency for all prices and/or amounts.

Usage : M1

Notes :

Ref.	Rep.	Name		EDIFICE Utilisation
C504		C CURRENCY DETAILS	R	
6347	an..3	M Currency details qualifier	M	2 = Reference currency
6345	an..3	C Currency, coded	R	Use ISO 4217, 3 alpha code
6343	an..3	C Currency qualifier	R	9 = Order currency
6348	n..4	C Currency rate base	N	
C504		C CURRENCY DETAILS	N	
6347	an..3	M Currency details qualifier	N	
6345	an..3	C Currency, coded	N	
6343	an..3	C Currency qualifier	N	
6348	n..4	C Currency rate base	N	
5402	n..12	C RATE OF EXCHANGE	N	
6341	an..3	C CURRENCY MARKET EXCHANGE, CODED	N	



**SG28 LIN-PIA-IMD-QTY-ALI-SG32-SG33-SG34-SG38-SG39**

**LIN LINE ITEM**

Function: A segment identifying a line item by its item number, and agreed to be the primary reference number between the buyer and seller.

The segment also carries a sequence number assigned to the line item within the message.

Usage : M1

Notes : For a line item referring to a service which has no coded identification, the primary identification is found in segment IMD, rather than in CO C212.

Ref.	Rep.	Name		EDIFICE Utilisation
1082	an..6	C LINE ITEM NUMBER	R	It is required to assign a number to the line items within a message. The number is assigned by the sender of the message. The first line item within a message will be numbered 1 and further line items will be incremented by 1 for each new line.  Primary reference BP = Buyer's part number DI = Distributor's part number (*) EN = International Article Numbering Association (EAN) MF = Manufacturer's (producer's) article number SRV = EAN.UCC Global Trade Item Number UP = UPC (Universal product code) VP = Vendor's (seller's) part number (*) EDIFICE code  9 = EAN (International Article Numbering association) 89 = Assigned by distributor 90 = Assigned by manufacturer 91 = Assigned by seller or seller's agent 92 = Assigned by buyer or buyer's agent 113 = US, UCC (Uniform Code Council)
1229	an..3	C ACTION REQUEST/NOTIFICATION, CODED	N	
C212		C ITEM NUMBER IDENTIFICATION	A	
7140	an..35	C Item number	R	
7143	an..3	C Item number type, coded	R	
1131	an..3	C Code list qualifier	N	
3055	an..3	C Code list responsible agency, coded	R	
C829		C SUB-LINE INFORMATION	N	
5495	an..3	C Sub-line indicator, coded	N	
1082	an..6	C Line item number	N	
1222	n..2	C CONFIGURATION LEVEL	N	
7083	an..3	C CONFIGURATION, CODED	N	

**SG28 LIN-PIA-IMD-QTY-ALI-SG32-SG33-SG34-SG38-SG39****PIA ADDITIONAL PRODUCT ID**

Function: A segment providing additional identification numbers for the line item.

Usage : D..10

Notes : The 5 internal repetitions of CO C212 may be used, but EDIFICE recommends to only use the first occurrence.

Ref.	Rep.	Name		EDIFICE Utilisation
4347	an..3	M PRODUCT ID. FUNCTION QUALIFIER	M	1 = Additional identification  AA = Product version number Release number of a product BP = Buyer's part number CL = Color number CV = Customs article number DI = Distributor's part number (*) DR = Drawing revision number DW = Drawing EC = Engineering change level EN = International Article Numbering Association (EAN) GS = General specification number MF = Manufacturer's (producer's) article number MN = Model number SG = Standard group of products (mixed assortment) SN = Serial number SRV = EAN.UCC Global Trade Item Number UP = UPC (Universal product code) VP = Vendor's (seller's) part number VX = Vendor specification number (*) EDIFICE code
C212		M ITEM NUMBER IDENTIFICATION	M	
7140	an..35	C Item number	R	
7143	an..3	C Item number type, coded	R	
1131	an..3	C Code list qualifier	N	
3055	an..3	C Code list responsible agency, coded	R	
C212		C ITEM NUMBER IDENTIFICATION	O	
7140	an..35	C Item number	R	
7143	an..3	C Item number type, coded	R	
1131	an..3	C Code list qualifier	N	
3055	an..3	C Code list responsible agency, coded	R	
C212		C ITEM NUMBER IDENTIFICATION	O	As for first CO C212
7140	an..35	C Item number	R	
7143	an..3	C Item number type, coded	R	
1131	an..3	C Code list qualifier	N	
3055	an..3	C Code list responsible agency, coded	R	
C212		C ITEM NUMBER IDENTIFICATION	O	As for first CO C212
7140	an..35	C Item number	R	
7143	an..3	C Item number type, coded	R	
1131	an..3	C Code list qualifier	N	
3055	an..3	C Code list responsible agency, coded	R	
C212		C ITEM NUMBER IDENTIFICATION	O	As for first CO C212
7140	an..35	C Item number	R	
7143	an..3	C Item number type, coded	R	
1131	an..3	C Code list qualifier	O	
3055	an..3	C Code list responsible agency, coded	R	

**SG28 LIN-PIA-IMD-QTY-ALI-SG32-SG33-SG34-SG38-SG39**

**IMD ITEM DESCRIPTION**

Function: A segment specifying ship to stock or ship to line quality and/or an additional description in clear or coded form, for the line item.

Usage : D 1

Notes :

Ref.	Rep.	Name		EDIFICE Utilisation
7077	an..3	C ITEM DESCRIPTION TYPE, CODED	D	C = Code (from industry code list) F = Free-form 3 = Ship to stock 26 = Ship to line Use DE 7009 for a coded description. If no code is available use DE 7008 instead.
7081	an..3	C ITEM CHARACTERISTIC, CODED	O	
C273		C ITEM DESCRIPTION	D	
7009	an..17	C Item description identification	A	
1131	an..3	C Code list qualifier	N	
3055	an..3	C Code list responsible agency, coded	N	
7008	an..35	C Item description	D	
7008	an..35	C Item description	O	
3453	an..3	C Language, coded	N	
7383	an..3	C SURFACE/LAYER INDICATOR, CODED	N	

**SG28 LIN-PIA-IMD-QTY-ALI-SG32-SG33-SG34-SG38-SG39**

**QTY QUANTITY**

Function: A segment specifying the total quantity for delivery for the line item.

Usage : D1

Notes : The quantity is the total line item quantity to be delivered according to instructions to be transmitted either by the DELFOR or DELJIT messages or by non-EDI means, or a combination of these.

Ref.	Rep.	Name	EDIFICE Utilisation
C186		M QUANTITY DETAILS	M
6063	an..3	M Quantity qualifier	M 21 = Ordered quantity
6060	n..15	M Quantity	M
6411	an..3	C Measure unit qualifier	R Use the following codes from UN/ECE Recommendation no.20, Codes for Units of Measurement: CLT = centilitre CMT = centimetre GRM = gram KGM = kilogram KMT = kilometre (*) LTR = litre MGM = milligram MMT = millimetre MTK = square metre MTQ = cubic metre MTR = metre PCE = piece (*) (*) EDIFICE code, not included in UN/ECE Recommendation No. 20 Other codes should be previously agreed between trading partners.

**SG28 LIN-PIA-IMD-QTY-ALI-SG32-SG33-SG34-SG38-SG39****ALI ADDITIONAL INFORMATION**

Function: A segment indicating the country of origin for the line item.

Usage : 01

Notes :

Ref.	Rep.	Name		EDIFICE Utilisation
3239	an..3	C COUNTRY OF ORIGIN, CODED	R	Use ISO 3166, 2 alpha code
9213	an..3	C TYPE OF DUTY REGIME, CODED	N	
4183	an..3	C SPECIAL CONDITIONS, CODED	N	
4183	an..3	C SPECIAL CONDITIONS, CODED	N	
4183	an..3	C SPECIAL CONDITIONS, CODED	N	
4183	an..3	C SPECIAL CONDITIONS, CODED	N	
4183	an..3	C SPECIAL CONDITIONS, CODED	N	

**SG32 PRI**

**PRI PRICE DETAILS**

Function: A segment specifying the line item price and the qualifying information.

Usage : M1

Notes :

Ref.	Rep.	Name		EDIFICE Utilisation
C509		C PRICE INFORMATION	R	
5125	an..3	M Price qualifier	M	AAA = Calculation net
5118	n..15	C Price	R	
5375	an..3	C Price type, coded	R	CA = Catalogue CP = Current price (*) CT = Contract DI = Distributor PV = Provisional price QT = Quote (* ) EDIFICE code
5387	an..3	C Price type qualifier	N	
5284	n..9	C Unit price basis	R	
6411	an..3	C Measure unit qualifier	R	Use the following codes from UN/ECE Recommendation no.20, Codes for Units of Measurement: CLT = centilitre CMT = centimetre GRM = gram KGM = kilogram KMT = kilometre (*) LTR = litre MGM = milligram MMT = millimetre MTK = square metre MTQ = cubic metre MTR = metre PCE = piece (*) (* ) EDIFICE code, not included in UN/ECE Recommendation No. 20 Other codes should be previously agreed between trading partners.
5213	an..3	C SUB-LINE PRICE CHANGE, CODED	N	

**SG33 RFF-DTM****RFF REFERENCE**

Function: A segment specifying the line item reference number as given by the buyer, or a document reference number.

Usage : M1

Notes : Where the buyer's line item reference number is to be specified use DE 1156 qualified by code 'LI' in DE 1153.

For all other references use DE 1154 with the relevant qualifier. If this information is given at header level it must not appear here.

Ref.	Rep.	Name		EDIFICE Utilisation
C506		M REFERENCE	M	
1153	an..3	M Reference qualifier	M	AAD = Contract addendum number CT = Contract number GC = Government contract number JB = Job number LI = Line item reference number Buyer's original line item number PR = Price quote number
1154	an..35	C Reference number	D	
1156	an..6	C Line number	D	Within an order this must be a unique number which will be the key for identification of the line item. The number is assigned by the buyer, and it can only be assigned once during the lifetime of the order. It will be used, where needed, to refer to the original line item on any subsequent transactions relating to the order. Normally, the first line number on an order will be numbered 1 and further line items will be incremented by 1 for each new line.
4000	an..35	C Reference version number	N	

**SG33 RFF-DTM**

**DTM DATE/TIME/PERIOD**

Function: A segment specifying the date of the reference document.

Usage : D 1

Notes :

Ref.	Rep.	Name		EDIFICE Utilisation
C507		M DATE/TIME/PERIOD	M	
2005	an..3	M Date/time/period qualifier	M	171 = Reference date/time
2380	an..35	C Date/time/period	R	
2379	an..3	C Date/time/period format qualifier	R	102 = CCYMMDD 203 = CCYMMDDHHMM 303 = CCYMMDDHHMMZZZ ZZZ = Time zone 304 = CCYMMDDHHMMSSZZZ ZZZ = Time zone X03 = CCYMMDDHHMMZZZZZ (*) ZZZZ = Time zone X04 = CCYMMDDHHMMSSZZZZZ (*) ZZZZ = Time zone (*) EDIFICE code



**SG34 PAC-QTY**

**PAC PACKAGE**

Function: A segment specifying the product package type.

Usage : M1

Notes :

Ref.	Rep.	Name		EDIFICE Utilisation
7224	n..8	C NUMBER OF PACKAGES	N	<p>The following codes are taken from EIDX documentation:                      BLK90 = Standard Bulk                      RAL90 = Standard Rail (semiconductor)                      REL90 = Standard Reel                      TRY90 = Standard Tray</p> <p>The following codes are taken from UN/ECE Recommendation no.21, (TDED 5.8):                      BA = Barrel                      BB = Bobbin                      BE = Bundle                      BG = Bag                      BQ = Bottle, protected cylindrical                      BV = Bottle, protected bulbous                      BX = Box                      CG = Cage                      CN = Container (*)                      CR = Crate                      CS = Case                      CT = Carton                      CX = Can, cylindrical                      DR = Drum                      EN = Envelope                      NE = Unpacked or unpackaged                      PC = Parcel                      PE = Pallet (*)                      PK = Package                      PU = Tray                      RL = Reel                      RO = Roll                      SW = Shrinkwrapped                      TN = Tin                      TU = Tube</p> <p>(*) EDIFICE code, not included in UN/ECE Recommendation No. 21                      Other codes should be previously agreed between trading partners.</p>
C531		C PACKAGING DETAILS	N	
7075	an..3	C Packaging level, coded	N	
7233	an..3	C Packaging related information, coded	N	
7073	an..3	C Packaging terms and conditions, coded	N	
C202		C PACKAGE TYPE	R	
7065	an..17	C Type of packages identification	R	
1131	an..3	C Code list qualifier	N	
3055	an..3	C Code list responsible agency, coded	D	
7064	an..35	C Type of packages	N	
C402		C PACKAGE TYPE IDENTIFICATION	N	
7077	an..3	M Item description type, coded	N	
7064	an..35	M Type of packages	N	
7143	an..3	C Item number type, coded	N	
7064	an..35	C Type of packages	N	
7143	an..3	C Item number type, coded	N	
C532		C RETURNABLE PACKAGE DETAILS	N	
8395	an..3	C Returnable package freight payment responsibility, coded	N	

Ref.	Rep.	Name	EDIFICE Utilisation	
8393	an..3	C Returnable package load contents, coded	N	

**SG34 PAC-QTY****QTY QUANTITY**

Function: A segment specifying the number of products contained in the package type.

Usage : 01

Notes :

Ref.	Rep.	Name		EDIFICE Utilisation
C186		M QUANTITY DETAILS	M	
6063	an..3	M Quantity qualifier	M	52 = Quantity per pack
6060	n..15	M Quantity	M	
6411	an..3	C Measure unit qualifier	N	

**SG38 TAX**

**TAX DUTY/TAX/FEE DETAILS**

Function: A segment specifying Value Added Tax, category and rate for the line item.

Usage : M1

Notes : CO C243 is not used when DE 5305 = 'E'.

Ref.	Rep.	Name		EDIFICE Utilisation
5283	an..3	M DUTY/TAX/FEE FUNCTION QUALIFIER	M	7 = Tax
C241		C DUTY/TAX/FEE TYPE	R	
5153	an..3	C Duty/tax/fee type, coded	R	VAT = Value added tax
1131	an..3	C Code list qualifier	N	
3055	an..3	C Code list responsible agency, coded	N	
5152	an..35	C Duty/tax/fee type	N	
C533		C DUTY/TAX/FEE ACCOUNT DETAIL	N	
5289	an..6	M Duty/tax/fee account identification	N	
1131	an..3	C Code list qualifier	N	
3055	an..3	C Code list responsible agency, coded	N	
5286	an..15	C DUTY/TAX/FEE ASSESSMENT BASIS	N	
C243		C DUTY/TAX/FEE DETAIL	D	
5279	an..7	C Duty/tax/fee rate identification	N	
1131	an..3	C Code list qualifier	N	
3055	an..3	C Code list responsible agency, coded	N	
5278	an..17	C Duty/tax/fee rate	R	Tax rate
5273	an..12	C Duty/tax/fee rate basis identification	N	
1131	an..3	C Code list qualifier	N	
3055	an..3	C Code list responsible agency, coded	N	
5305	an..3	C DUTY/TAX/FEE CATEGORY, CODED	R	AA = Lower rate VAT at a lower rate than standard rate E = Exempt from tax S = Standard rate Z = Zero rated goods
3446	an..20	C PARTY TAX IDENTIFICATION NUMBER	N	

**SG39 NAD**

**NAD NAME AND ADDRESS**

Function: A segment identifying the manufacturer's code, for the line item.

Usage : M1

Notes :

Ref.	Rep.	Name		EDIFICE Utilisation
3035	an..3	M PARTY QUALIFIER	M	MF = Manufacturer of goods
C082		C PARTY IDENTIFICATION DETAILS	R	
3039	an..35	M Party id. identification	M	Manufacturer's code
1131	an..3	C Code list qualifier	D	
3055	an..3	C Code list responsible agency, coded	R	To be agreed between trading partners
C058		C NAME AND ADDRESS	N	
3124	an..35	M Name and address line	N	
3124	an..35	C Name and address line	N	
3124	an..35	C Name and address line	N	
3124	an..35	C Name and address line	N	
3124	an..35	C Name and address line	N	
C080		C PARTY NAME	N	
3036	an..35	M Party name	N	
3036	an..35	C Party name	N	
3036	an..35	C Party name	N	
3036	an..35	C Party name	N	
3036	an..35	C Party name	N	
3045	an..3	C Party name format, coded	N	
C059		C STREET	N	
3042	an..35	M Street and number/p.o. box	N	
3042	an..35	C Street and number/p.o. box	N	
3042	an..35	C Street and number/p.o. box	N	
3042	an..35	C Street and number/p.o. box	N	
3164	an..35	C CITY NAME	N	
3229	an..9	C COUNTRY SUB-ENTITY IDENTIFICATION	N	
3251	an..9	C POSTCODE IDENTIFICATION	N	
3207	an..3	C COUNTRY, CODED	N	

**UNS SECTION CONTROL**

---

Function: A service segment separating detail and summary section.

Usage : M1

Notes :

Ref.	Rep.	Name	EDIFICE Utilisation	
0081	a1	M SECTION IDENTIFICATION	M	S = Detail/summary section separation

**UNT MESSAGE TRAILER**

Function: A service segment ending, and providing information for checking the completeness of a message.

Usage : M1

Notes : Refer to EDIFICE Utilisation of the UN/EDIFACT Service Segments, Issue EDDS04.

Ref.	Rep.	Name	EDIFICE Utilisation	
0074	n..6	M NUMBER OF SEGMENTS IN A MESSAGE	M	Count of all segments in the message, UNH and UNT included.
0062	an..14	M MESSAGE REFERENCE NUMBER	M	Must be the same reference number as in DE 0062 of the UNH segment of this message.

## **EXAMPLES**

In the following 3 example messages the different usages are found entirely in the different use of the Header DTM and Detail QTY segments. All other information is identical.

### EXAMPLE 1: BLANKET ORDER FOR A DEFINED TIME PERIOD

This example corresponds to EDIFICE Functional Definition Usage 1

```
UNB+UNOC:3+234567891:1:X+198765432:1:X+971201:1924+66+X:AA+ORDERS++1+X+1'  
UNH+1+ORDERS:D:97A:UN:EDBO03'  
BGM+221+6785432+9'  
DTM+137:19961128:102'  
DTM+158:19970101:102'  
DTM+159:19971231:102'  
RFF+CT:999456'  
NAD+BY+MAGIMAX LTD::92'  
CTA+PD+PETER SMITH'  
COM+0756-551234:TE'  
CTA+SC+:M BRODY'  
COM+0756-551459:TE'  
NAD+SE+PISCES SEMICONDUCTORS::92'  
CUX+2:USD:9'  
LIN+1++ABC0071:BP::92'  
PIA+1+1167892:VP::91'  
IMD++3'  
ALI+US'  
PRI+AAA:2.45:CT::1:PCE'  
RFF+CT:M5311-93:24'  
UNS+S'  
UNT+21+1'  
UNZ+1+66'
```



EXAMPLE 2: BLANKET ORDER FOR A DEFINED QUANTITY FOR DELIVERY

This example corresponds to EDIFICE Functional Definition Usage 2

UNB+UNOC:3+234567891:1:X+198765432:1:X+971201:1924+66+X:AA+ORDERS++1+X+1'  
UNH+1+ORDERS:D:97A:UN:EDBO03'  
BGM+221+6785432+9'  
DTM+137:19961128:102'  
RFF+CT:999456'  
NAD+BY+MAGIMAX LTD::92'  
CTA+PD+PETER SMITH'  
COM+0756-551234:TE'  
CTA+SC+:M BRODY'  
COM+0756-551459:TE'  
NAD+SE+PISCES SEMICONDUCTORS::92'  
CUX+2:USD:9'  
LIN+1++ABC0071:BP::92'  
PIA+1+1167892:VP::91'  
IMD++3'  
QTY+21:100000:PCE'  
ALI+US'  
PRI+AAA:2.45:CT::1:PCE'  
RFF+CT:M5311-93:24'  
UNS+S'  
UNT+20+1'  
UNZ+1+66'

EXAMPLE 3: BLANKET ORDER FOR A DEFINED QUANTITY FOR DELIVERY AND TIME PERIOD

This example corresponds to EDIFICE Functional Definition Usage 3

UNB+UNOC:3+234567891:1:X+198765432:1:X+971201:1924+66+X:AA+ORDERS++1+X+1'  
UNH+1+ORDERS:D:97A:UN:EDBO03'  
BGM+221+6785432+9'  
DTM+137:19961128:102'  
DTM+158:19970101:102'  
DTM+159:19971231:102'  
RFF+CT:999456'  
NAD+BY+MAGIMAX LTD::92'  
CTA+PD+PETER SMITH'  
COM+0756-551234:TE'  
CTA+SC+:M BRODY'  
COM+0756-551459:TE'  
NAD+SE+PISCES SEMICONDUCTORS::92'  
CUX+2:USD:9'  
LIN+1++ABC0071:BP::92'  
PIA+1+1167892:VP::91'  
IMD++3'  
QTY+21:100000:PCE'  
ALI+US'  
PRI+AAA:2.45:CT::1:PCE'  
RFF+CT:M5311-93:24'  
UNS+S'  
UNT+22+1'  
UNZ+1+66'